

| CONNECTOR ID | DESCRIPTION   |
|--------------|---------------|
| C            | SIGNAL COMMON |
| L            | LINE 1        |
| G            | GROUND        |
| N            | LINE 2        |
| 1            | LOW (PWM)     |
| 2            | MED-LOW       |
| 3            | MED           |
| 4            | MED-HIGH      |
| 5            | HIGH          |

| NAMEPLATE DATA |              |
|----------------|--------------|
| MODEL          | 5SME39SXL449 |
| CUSTOMER       | DEF PUR      |
| STOCK No.      | 6210E        |
| H.P.           | 1            |
| RPM            | 1075         |
| VOLTS          | 208-230      |
| HZ             | 60/50        |
| AMPS           | 7.6          |
| ROTATION       | CCW/CW       |
| MTG POSITION   | HOR/VSD      |

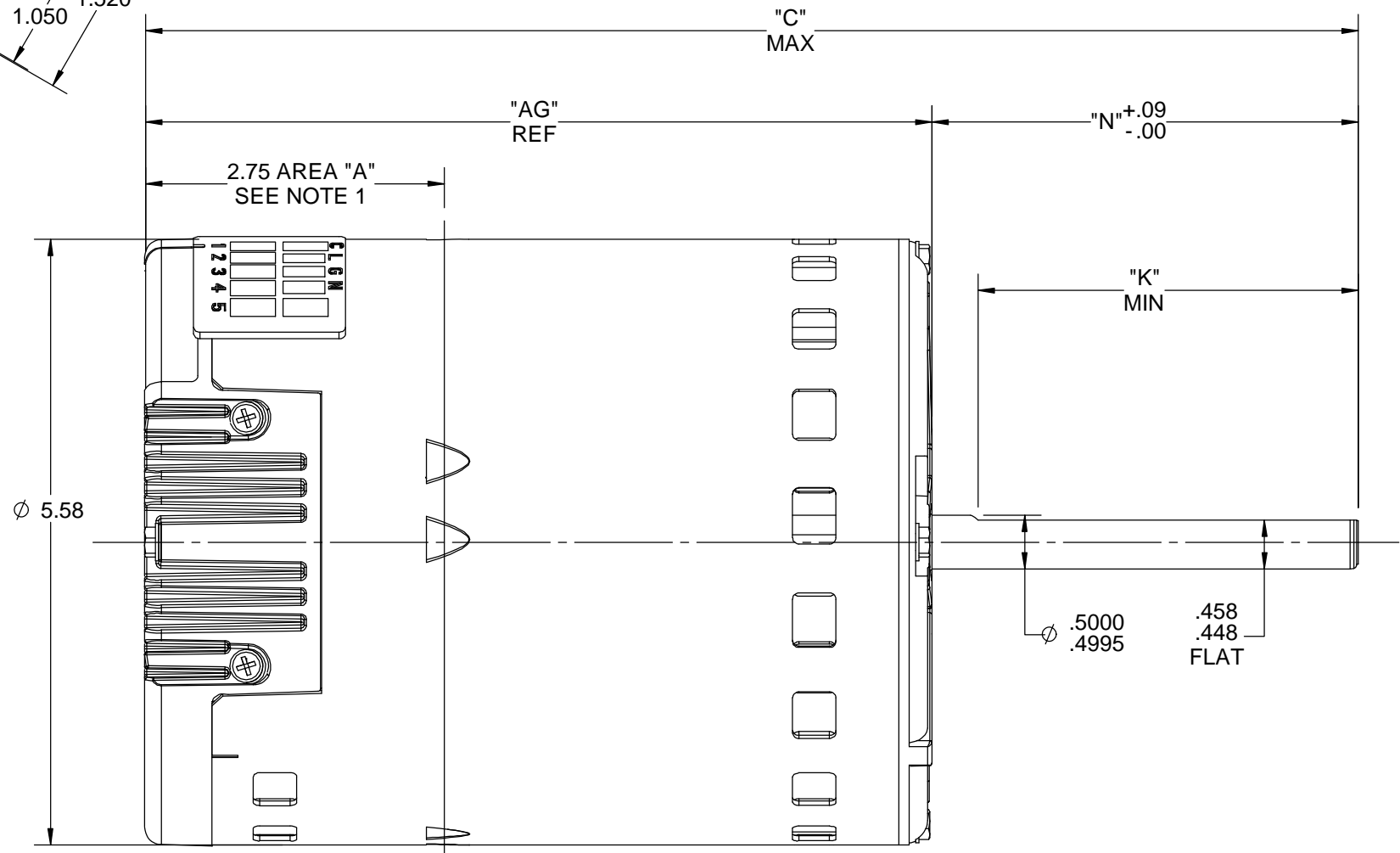
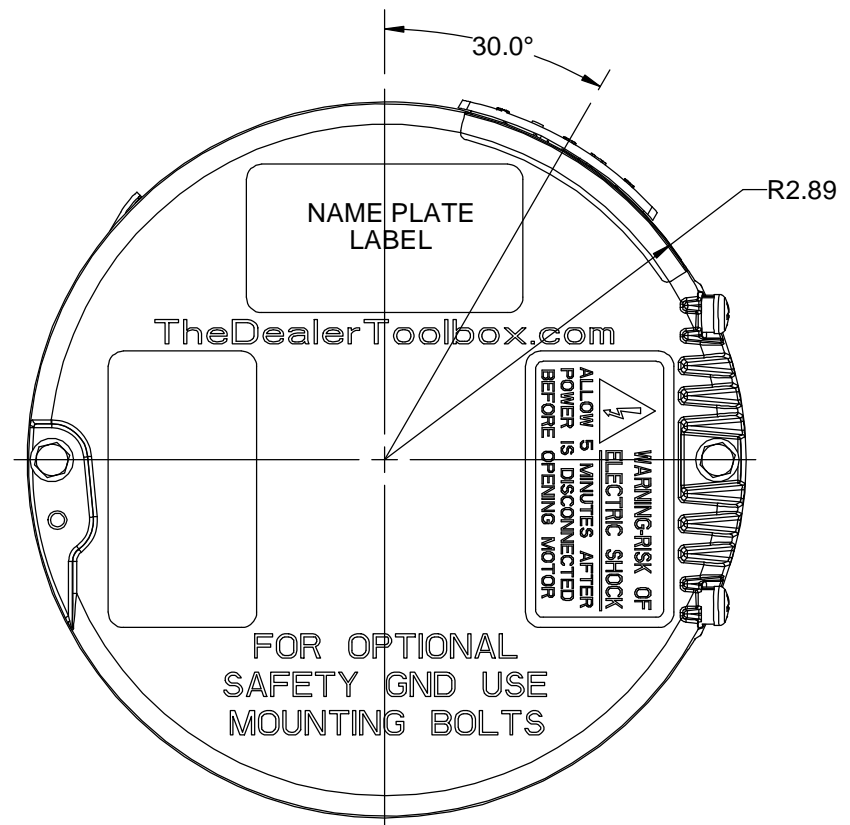
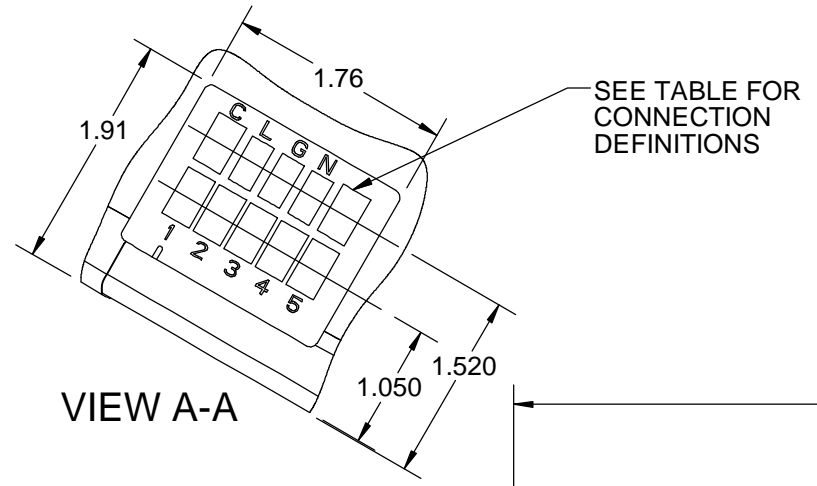

|       |      |      |      |
|-------|------|------|------|
| 12.20 | 4.92 | 4.50 | 7.25 |
| C     | N    | K    | AG   |

- NOTE:
- BELLY BAND MUST NOT BE PLACED WITHIN AREA "A"
  - APPROXIMATE WEIGHT IS 19.0LB

|   |                       |                    |
|---|-----------------------|--------------------|
| DRAWING REVISION<br>E   | REVISION BY<br>KEP    | DATE<br>12/22/2017 |
| ECO<br>ECO-0129397  | APPROVED BY<br>ANDREA | DATE<br>12/18/2017 |
| ECO DESCRIPTION<br>UPDATED AS PER ECO REQUEST   |                       |                    |
| <small>COPYRIGHT REGAL BELOIT AMERICA, INC. ALL RIGHTS RESERVED. PROPRIETARY AND CONFIDENTIAL INFORMATION - THIS DOCUMENT IS THE PROPERTY OF REGAL BELOIT AMERICA, INC. ("OWNER") AND CONTAINS OWNER'S PROPRIETARY INFORMATION. ANY PERSON, CORPORATION OR OTHER FIRM RECEIVING IT IS DEEMED, BY RECEIVING IT, TO AGREE THAT IT, AND/OR ANY PART OF IT, SHALL NOT BE DISCLOSED TO ANY PERSON, CORPORATION OR OTHER ENTITY, DUPLICATED, AND/OR USED, EXCEPT AS EXPRESSLY APPROVED IN WRITING IN ADVANCE BY OWNER. THIS DOCUMENT SHALL BE RETURNED TO OWNER UPON REQUEST. IT MAY BE SUBJECT TO CERTAIN RESTRICTIONS UNDER APPLICABLE EXPORT CONTROL LAWS AND REGULATIONS.</small> |                       |                    |

|                        |  |
|------------------------|--|
| DRAWN BY<br>KEP        |  |
| DATE<br>12/06/2012     |  |
| APPROVED BY<br>MANZ    |  |
| DATE<br>12/06/2012     |  |
| REFERENCE              |  |
| THIRD ANGLE PROJECTION |  |

|   |                                |
|---|--------------------------------|
| Regal Beloit America, Inc.                  |                                |
| DESCRIPTION<br><b>OUTLINE</b><br>Endura Pro |                                |
| MATERIAL                                    | PROCESS/FINISH                 |
| SIZE<br>B                                   | DRAWING NUMBER<br>5SME39SXL449 |
| SHEET<br>1 OF 1                             |                                |