

MODEL
3DS3F46K
3DA3R10M
3DB3R12M
3DF3F40K
3DF3R15M

THIS DRAWING REFERENCES CORESENSE PROTECTION COMPRESSORS WITH A MODEL NUMBER ENDING WITH -C58

NOTES:

- 1 ALL TOLERANCES ARE ±0.10 EXCEPT INDUSTRY STANDARDS APPLY TO FITTINGS AND VALVES.
- 2 THIS DIMENSION IS NECESSARY FOR COVER REMOVAL.
3. ALL PIPE PLUGS AND FITTINGS IN THE CYLINDER HEAD ARE HIGH PRESSURE CONNECTIONS.

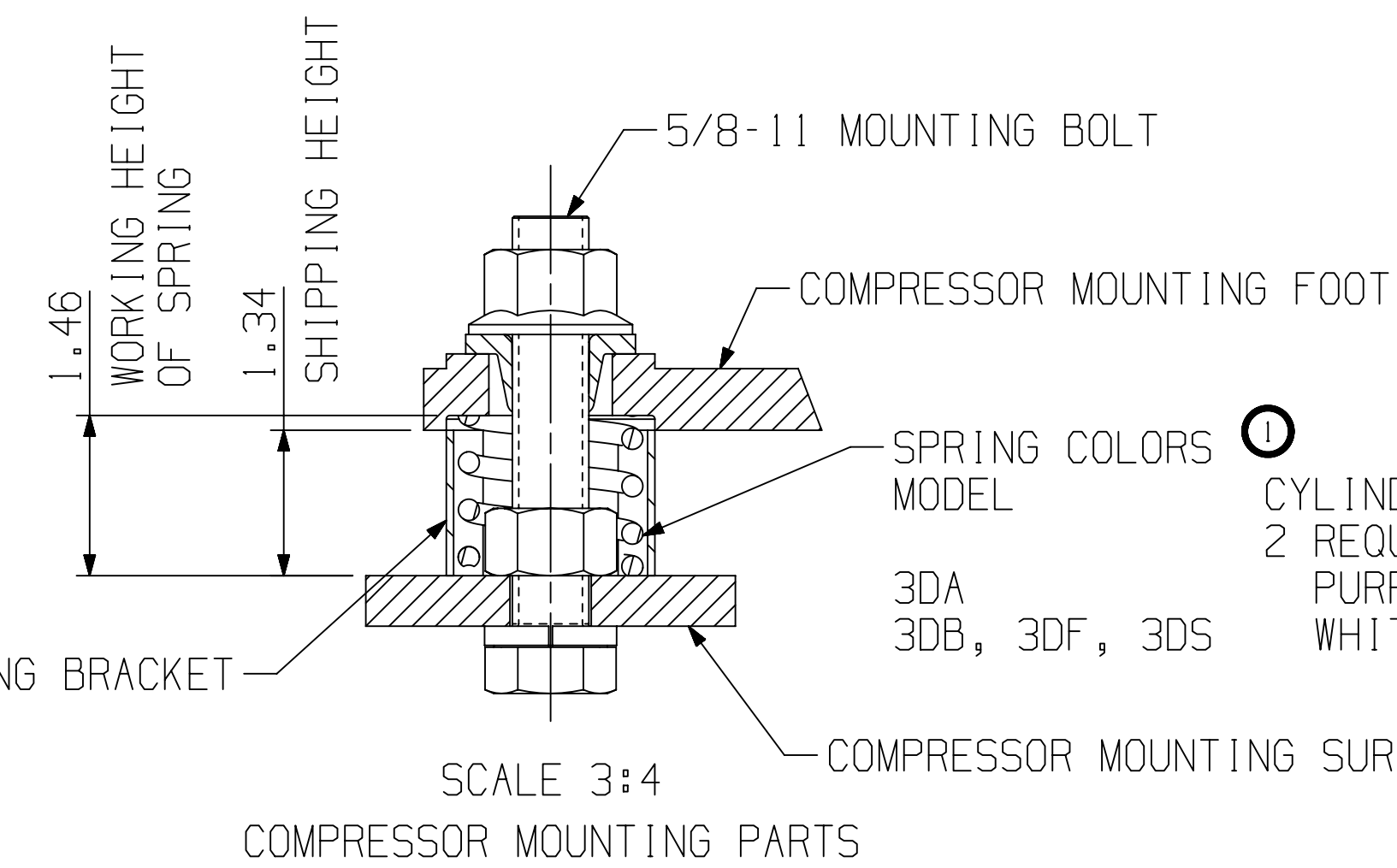
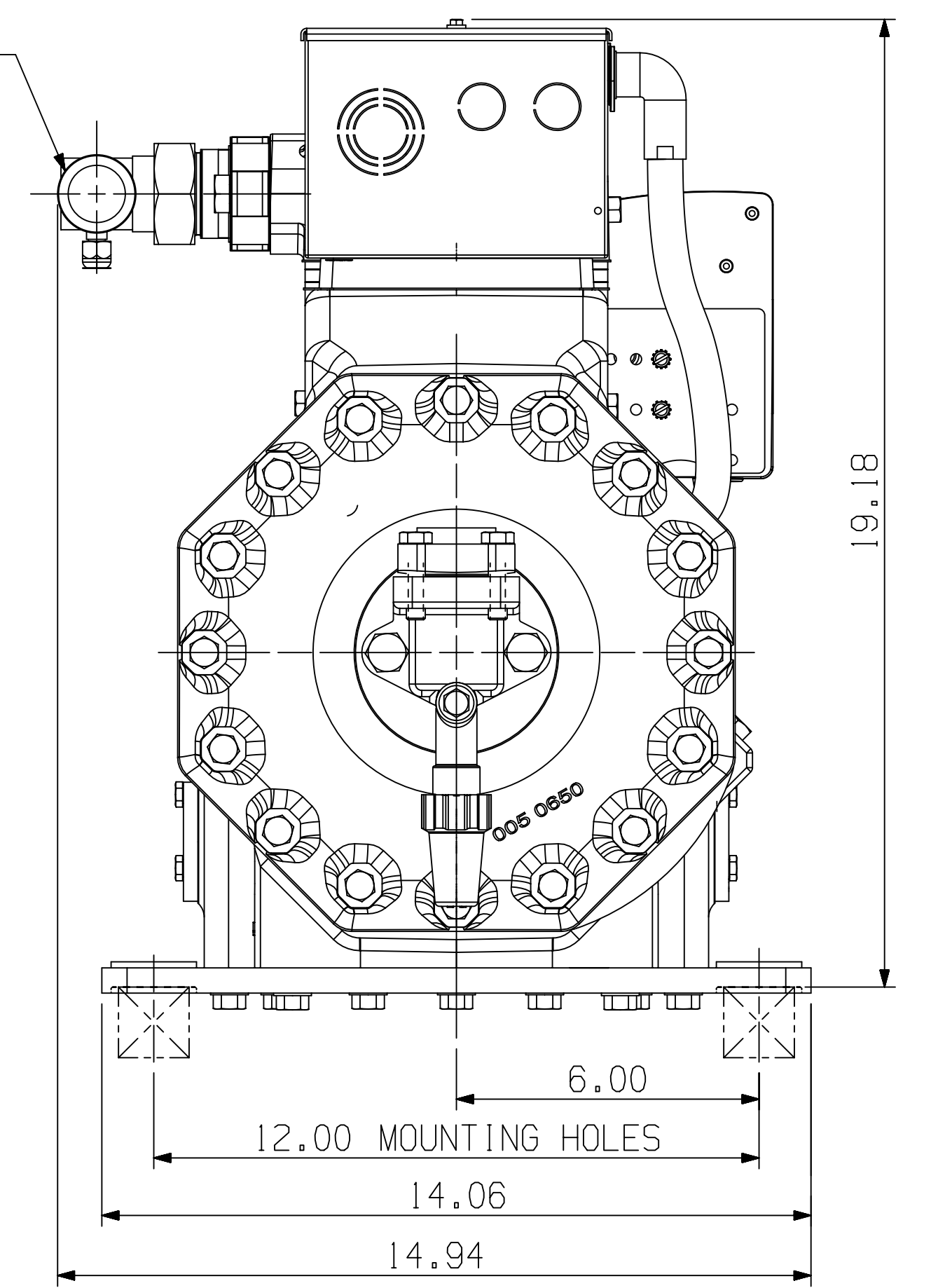
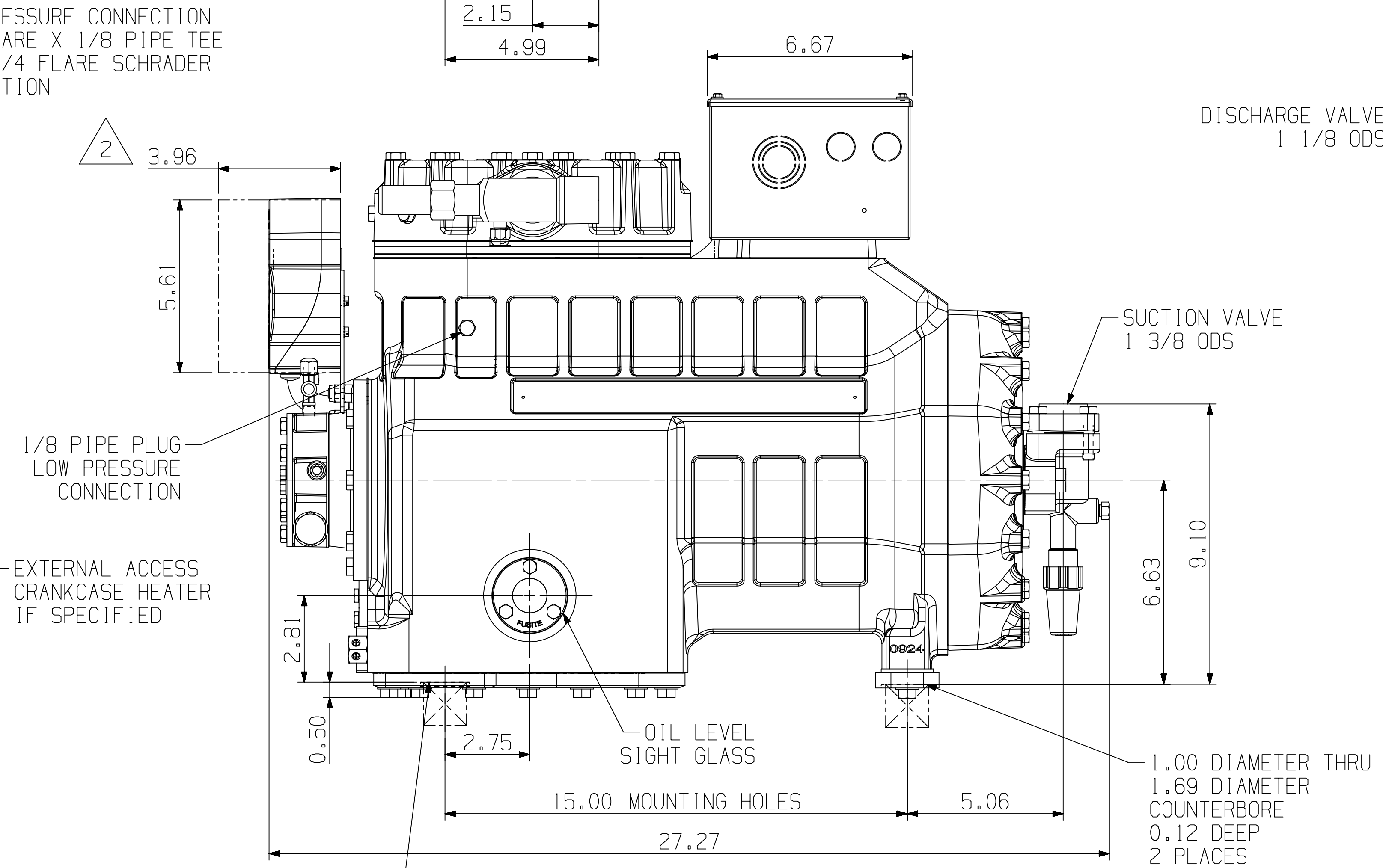
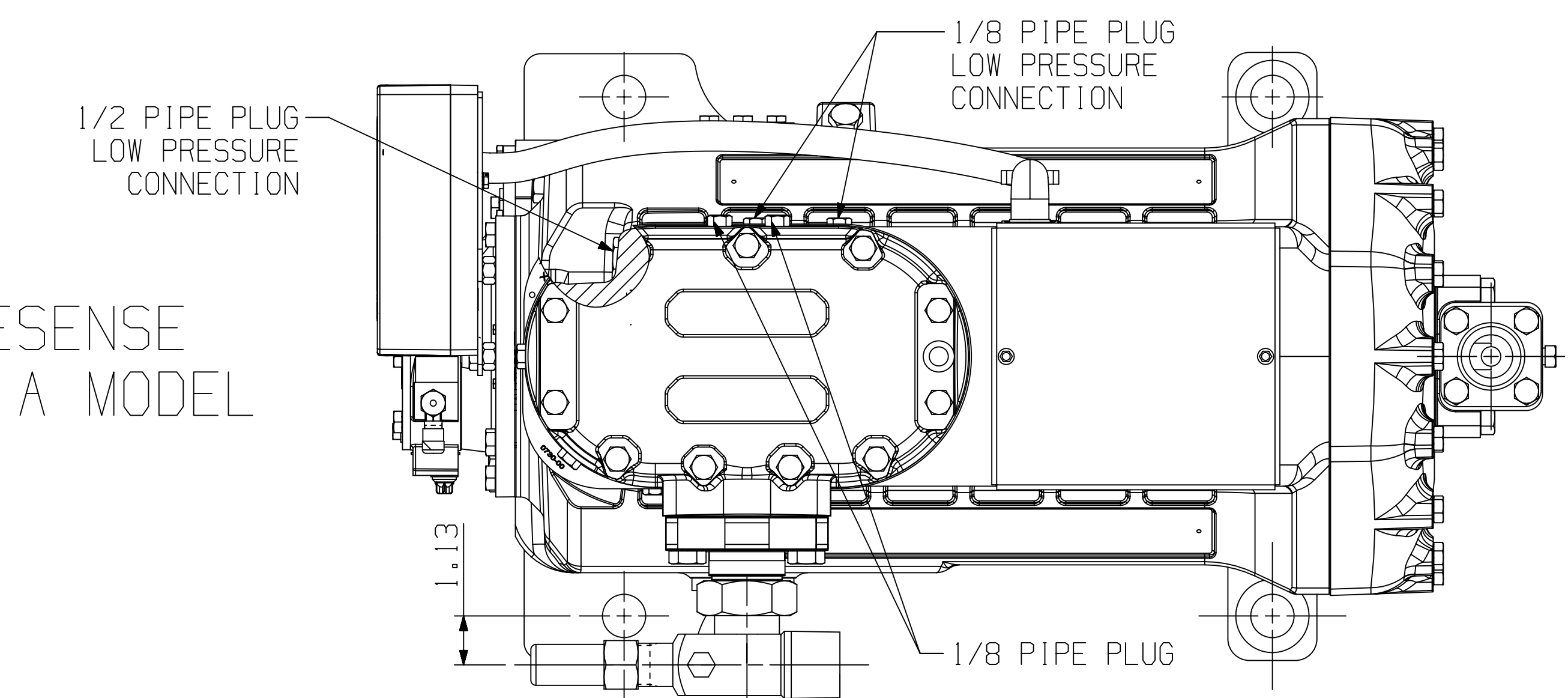
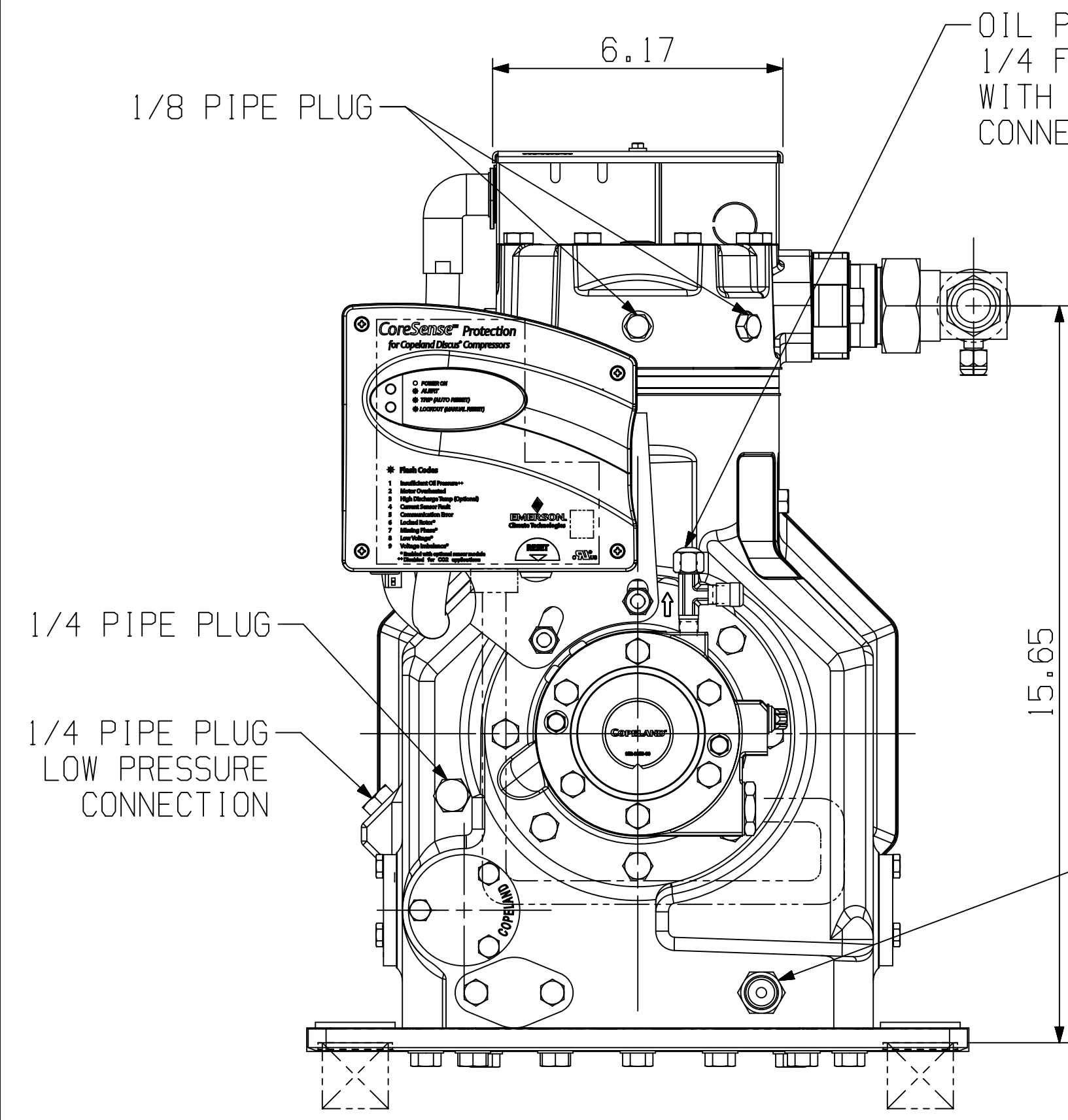

① SPRING COLORS MODEL
 3DA 3DB, 3DF, 3DS
 CYLINDER END 2 REQUIRED PURPLE WHITE
 MOTOR END 2 REQUIRED PURPLE PURPLE

1.00 DIAMETER THRU 1.58 DIAMETER COUNTERBORE 0.17 DEEP 2 PLACES

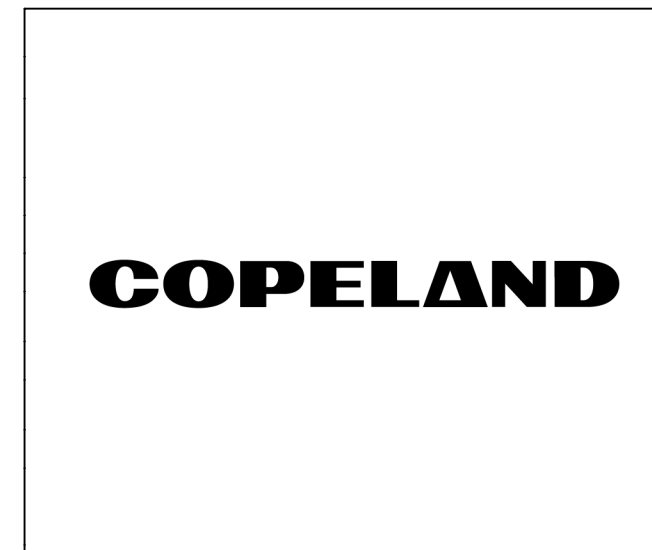

INTERPRET PER ASME Y14.5M-1994 AND COPELAND DESIGN STANDARDS DS2002

DO NOT SCALE DRAWING

CRITICAL PRODUCT CHARACTERISTICS

UNLESS OTHERWISE SPECIFIED DIMENSIONS ARE INCH OR (MILLIMETER)

TOLERANCES:
 2-PLACE +
 3-PLACE +
 ANGULAR ± .1

ECN325315	2	UPDATED TITLE BLOCK	09-12-23		
ECN321224	1	ADDED MODELS	06-21-22	MINH	OSP
ECN320941	0	RELEASED	05-18-22	MINH	OSP
ENG NOTICE NO.	REV. NO.	REVISIONS	DATE	BY	CHKD
7		CONFIDENTIALITY NOTICE			
THIS DRAWING AND INFORMATION CONTAINED HEREIN ARE THE EXCLUSIVE PROPERTY OF COPELAND LP AND/OR ITS AFFILIATES (COLLECTIVELY "COPELAND") AND SHALL BE RETURNED UPON DEMAND AND SHALL NOT BE REPRODUCED IN WHOLE OR IN PART, DISCLOSED TO ANYONE ELSE OR USED, WITHOUT THE WRITTEN CONSENT OF COPELAND.					
MATERIAL SPECIFICATION		DRAWN BY	SUPERSEDES DWG NO /		REV NO /
N/A		MINH			
		DATE	SCALE	DATE FORMAT:	
		05-18-22	3:8	MM-DD-YY	
TITLE			DRAWING NUMBER	SHEET 1 OF 1 DWG	
REF DWG-COPE COMP ASSM			497-3956-00	4	
			SIZE		